

# GROUNDING

## FRAME GROUNDING SPACER

**The grounding function is combined with resin-made spacer. (PATENTED)**

Resin made spacer combined with tin plated phosphor bronze is used for suppression of EMI and ESD on the PCB.

### Specifications:

- |                            |                               |
|----------------------------|-------------------------------|
| - Material Resin Part      | Polyphenylene ether           |
| Metallic Part              | Tin plated phosphor bronze    |
| - UL standard (resin part) | UL94V-0                       |
| - Contact resistance       | $10^{-2} \sim 10^{-4} \Omega$ |

### Features

- Pressure developed by plastic and metal fingers provide contact over p.c. card for excellent electrical current passage.
- Stable contact resistance is gained.
- Contact resistance does not vary in the heat cycle test.
- Even if the screw can not stand at the center of the PCB, the ground can be provided as desired.
- Maintenance can be carried out easily.
- The number of parts is reduced.
- The cost is reduced considerably.

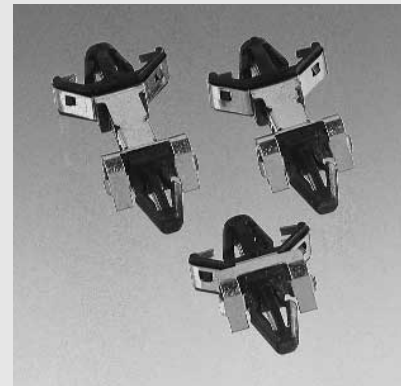

Part No.	Unit: mm	
	A	B
FGS-3S	9.8	20.3
FGS-4S	11.4	21.9
FGS-6S	14.4	24.9
FGS-8S	17.7	28.2
FGS-9S	20.0	30.5

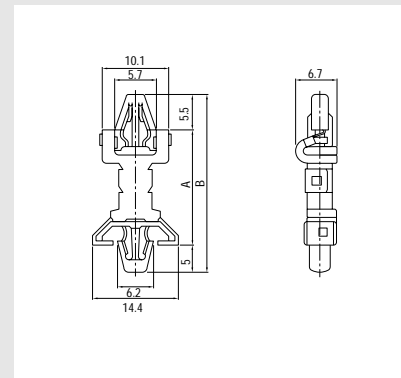

## FG edge spacer (FGES-10)

### FG edge spacer

A grounding function is added to the supporting structure as well as open/close functions of the printed circuit board. Frame grounding can be taken from the P.C. board spacer in the equipment which requires opening/closing of the P.C. board during maintenance.

### Specifications

- Material:  
Resin portion: PPHOX  
Metal portion: tin plated phosphor bronze
- Applicable board thickness:  
PC board 1.6mm  
Chassis side t 0.8mm-t 2.3mm

### Features

- Fire-resistant material is used (equivalent to UL94V-0)

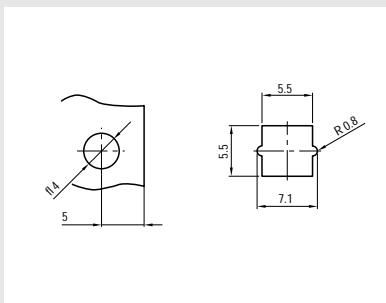
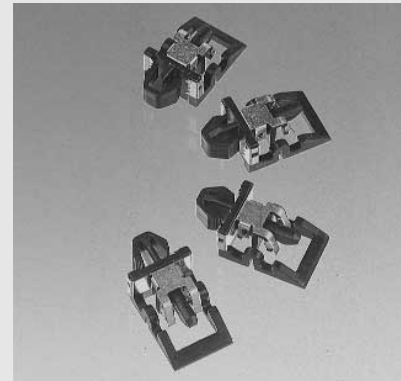

Article No. FGES-10

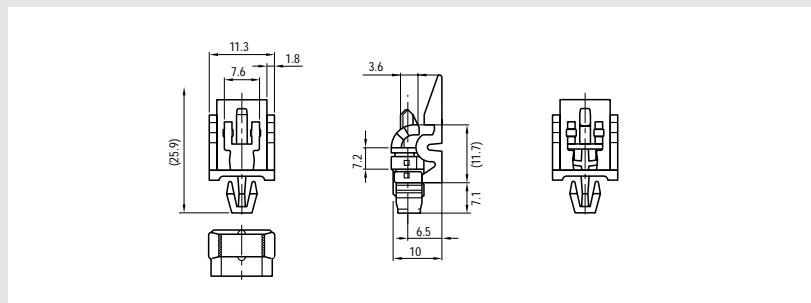

PWB side t=1.6±0.15 chassis side t=0.8~2.3

\*Remarks: Two installation holes are placed on the same axis.